

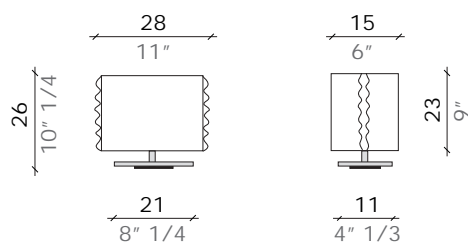

MIDA 23 - T

Design PAOLO CREPAX · SILVIO ZANON 2001

Lampada in vetro bianco e cristallo eseguita a mano. Struttura cromata spazzolata.

- *Hand-made, white and crystal plate-glass lamp. Brushed chromium-plated frame.*
- *Hangearbeitete Leuchte aus weißem Kristallglas. Gebürstete Chromfassung.*
- *Lampe en verre blanc et verre glace fait main. Structure chromée brossée.*
- *Lámpara de vidrio blanco y cristal fabricada a mano. Estructura cromada cepillada.*



	K max 1x100W	E27
	AL max 1x150W	E27





MIDA 46 - T



Design | PAOLO CREPAX - SILVIO ZANON 2001

Lampada in vetro bianco e cristallo eseguita a mano. Struttura cromata spazzolata.

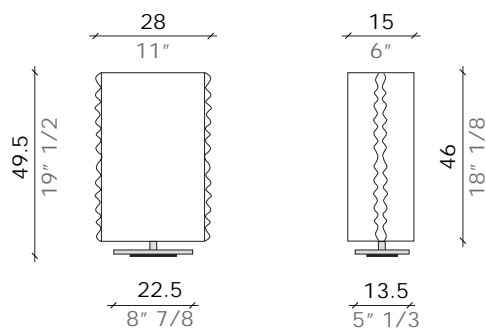
- *Hand-made, white and crystal plate-glass lamp. Brushed chromium-plated frame.*
- *Hangearbeitete Leuchte aus weißem Kristallglas. Gebürstete Chromfassung.*
- *Lampe en verre blanc et verre glace fait main. Structure chromée brossée.*
- *Lámpara de vidrio blanco y cristal fabricada a mano. Estructura cromada cepillada.*



176

	K max 1x150W	E27
	AL max 1x150W	E27



