

MIDA - P



Design | PAOLO CREPAX - SILVIO ZANON 2001

Lampada in vetro bianco e cristallo eseguita a mano. Struttura grigio metallizzata.

- *Hand-made, white and crystal plate-glass lamp. Metal grey frame.*
- *Hangearbeitete Leuchte aus weißem Kristallglas. Gebürstete grau metallisiert.*
- *Lampe en verre blanc et verre glace fait main. Structure gris métallisé.*
- *Lámpara de vidrio blanco y cristal fabricada a mano. Estructura gris metalizado.*

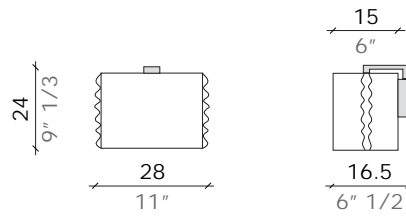

MIDA 23-P

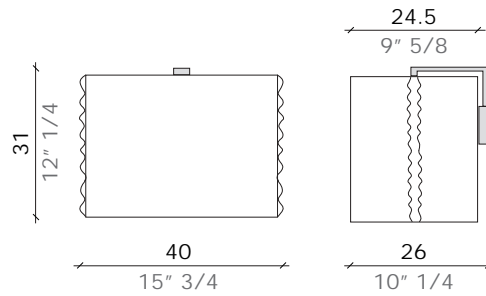

	K max 1x100W	E27
	AL max 1x150W	E27

MIDA 30-P



	K max 1x150W	E27
	AL max 1x150W	E27

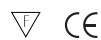



MIDA 46 - P



Design PAOLO CREPAX - SILVIO ZANON 2001

Lampada in vetro bianco e cristallo eseguita a mano. Struttura grigio metallizzata.

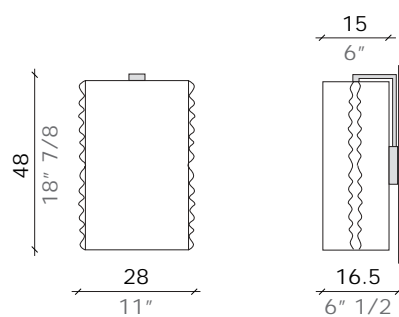
- *Hand-made, white and crystal plate-glass lamp. Metal grey frame.*
- *Hängearbeitete Leuchte aus weißem Kristallglas. Gebürstete grau metallisiert.*
- *Lampe en verre blanc et verre glace fait main. Structure gris métallisé.*
- *Lámpara de vidrio blanco y cristal fabricada a mano. Estructura gris metalizado.*



172

	K max 1x150W	E27
	AL max 1x150W	E27



